

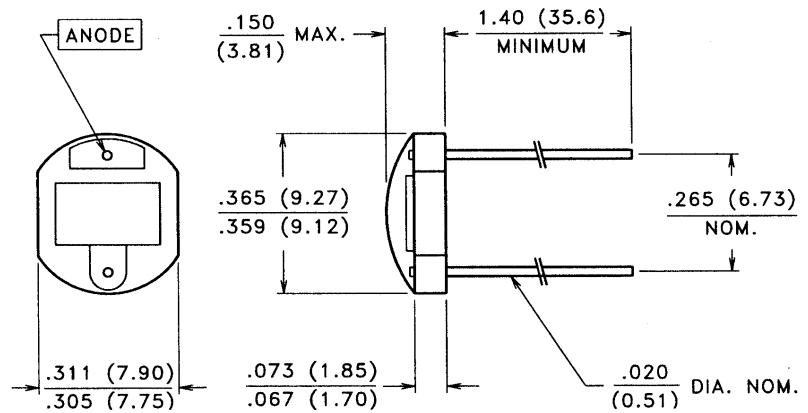

## PACKAGE DIMENSIONS inch (mm)



CASE 13 CERAMIC  
CHIP ACTIVE AREA: .026 in<sup>2</sup> (16.73 mm<sup>2</sup>)

## PRODUCT DESCRIPTION

Planar silicon photodiode mounted on a two lead ceramic substrate and coated with a thick layer of clear epoxy. These diodes exhibit low dark current under reverse bias and fast speed of response.

## ABSOLUTE MAXIMUM RATINGS

Storage Temperature: -20°C to 75°C  
Operating Temperature: -20°C to 75°C

## ELECTRO-OPTICAL CHARACTERISTICS @ 25°C

SYMBOL	CHARACTERISTIC	TEST CONDITIONS	VTD31AA			UNITS
			Min.	Typ.	Max.	
I <sub>SC</sub>	Short Circuit Current	H = 5 mW/cm <sup>2</sup> , 2850 K	150		225	μA
TC I <sub>SC</sub>	I <sub>SC</sub> Temperature Coefficient	2850 K		.20		%/°C
V <sub>OC</sub>	Open Circuit Voltage	H = 5 mW/cm <sup>2</sup> , 2850 K		350		mV
TC V <sub>OC</sub>	V <sub>OC</sub> Temperature Coefficient	2850 K		-2.0		mV/°C
I <sub>D</sub>	Dark Current	H = 0, V <sub>R</sub> = 15 V			50	nA
C <sub>J</sub>	Junction Capacitance	H = 0, V = 0 V			500	pF
S <sub>R</sub>	Sensitivity	@ Peak		.55		A/W
λ <sub>range</sub>	Spectral Application Range		400		1150	nm
λ <sub>p</sub>	Spectral Response - Peak			860		nm
V <sub>BR</sub>	Breakdown Voltage		5			V
θ <sub>1/2</sub>	Angular Resp.-50% Resp. Pt.			±60		Degrees